

SINCE 1908
wessels
 company

SUBMITTAL

**TYPE: WESS-VENT – HIGH VELOCITY
 AIR & DIRT SEPARATOR**

MODELS: WVA-2HV TO WVA-12HV

SUBMITTAL SHEET No. WVAHV-110B

Date: 7/03

JOB _____ Unit Tag No. _____ Engineer _____ Contractor _____	Wessels Representative _____ _____ _____ Order No. _____ Date _____ Submitted By _____ Date _____ Approved By _____ Date _____
---	---

DESCRIPTION

Wessels WVA-HV (High Velocity) series Air & Dirt Separators are designed to eliminate entrained air and separate debris associated with start-up and maintenance of any hydronic system. The design incorporates a skim valve, used to eliminate floating debris, a removable end cover for coalescing medium access, and an air vent to automatically release air from the separator. The design and construction conforms to ASME Section VIII, Div.1

CONSTRUCTION

Shell: Carbon Steel
 Coalescing Medium: Stainless Steel
 Blow Down Valve (optional): Bronze
 Skim Valve (optional): Bronze
 Vent: (optional): Stainless Steel

PERFORMANCE LIMITATIONS

Maximum Design Temperature: 250°F
 Maximum Design Pressure: 125 PSIG

DIMENSIONS AND WEIGHTS

MODEL	CONN. SIZE	FLOW GPM	D (IN.)	H (IN.)	W (IN.)	A (IN.)	B (IN.)	WT LBS.
WVA-2HV	2	105	9	33	15 1/4	11 1/2	8 5/8	110
WVA-2HV-NPT	2 NPT	105	9	33	10 3/8	11 1/2	8 5/8	100
WVA-2.5HV	2 1/2	155	10	33	15 3/4	11 1/2	8 5/8	140
WVA-2.5HV-NPT	2 1/2 NPT	155	10	33	11	11 1/2	8 5/8	125
WVA-3HV	3	225	11	42	20 1/4	14 1/2	8 5/8	175
WVA-3HV-NPT	3 NPT	225	11	42	12 1/2	14 1/2	8 5/8	155
WVA-4HV	4	405	13 1/2	42	20 5/8	14 1/2	8 5/8	275
WVA-4HV-NPT	4 NPT	405	13 1/2	42	15	14 1/2	8 5/8	235
WVA-5HV	5	630	16	59	27 3/4	19 1/2	8 5/8	475
WVA-6HV	6	910	19	59	27 3/4	19 1/2	8 5/8	525
WVA-8HV	8	1610	23 1/2	75	33 5/8	24 1/2	8 5/8	825
WVA-10HV	10	2450	27 1/2	92	37 1/2	32 1/2	8 5/8	1275
WVA-12HV	12	3500	32	110	42 1/2	38	8 5/8	2050

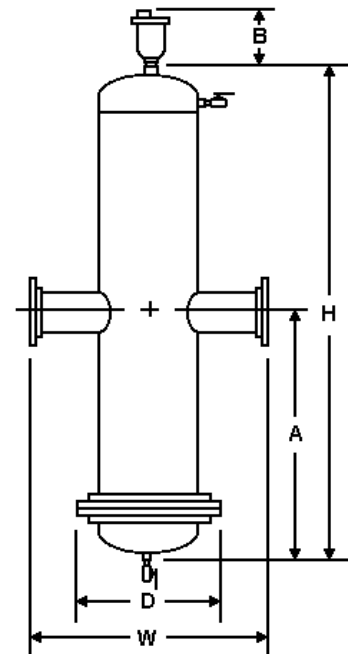

SPECIFICATION

Furnish and install on the plans and described herein, a Wess-Vent WVA-HV High Velocity Air & Dirt Separator as manufactured by Wessels Company. Each separator must be designed with a blowdown valve, skim valve, and automatic air vent. The separator must also utilize in its design a stainless steel coalescing medium to aid in the separation of air and dirt in the system entrained water. The separator must be constructed in accordance with the latest revision of the ASME Boiler and Pressure Vessel Code and stamped 125 psi working pressure.

Each separator shall be Wessels model WVA ___-HV or approved equal.